

# Installation Instructions for Fortress Vertical Cable Panel System with UB-05 Brackets and Fe<sup>26</sup> Posts

It is the responsibility of the installer to meet all code and safety requirements, and to obtain all required building permits. The deck and railing installer should determine and implement appropriate installation techniques for each installation situation. Fortress Railing Products and its distributors shall not be held liable for improper or unsafe installations.

Fortress Fe<sup>26</sup> Posts must always be secured to the deck framing. Fortress Fe<sup>26</sup> Posts should never be attached to only the deck boards.

## Read Instructions Completely Before Starting Installation

### Note

When cutting Fortress railing, it is very important to complete the following at cut points.

- Remove all metal shavings from the cut area
- File any sharp edges left by cutting. Thoroughly wipe and remove any filings, grime or dirt from the railing.
- Apply two coats of Fortress zinc based touch-up paint to the cut area. If touch up is at rail ends, allow paint to dry before connecting bracket to post.
- Be sure to remove any metal shavings from the surface of deck, patio or balcony to prevent stains on the deck surface.

### Torx Safety Tips

- Always pre-drill holes with a 3/16" drill bit.
- Always use the lowest speed setting on drill.
- To reduce chance of bit breakage, start tightening with drill on low torque setting and work up until screw is secured.

### Required Materials

Miter saw with cut off blade or Metal Cutting Reciprocating Saw, Drill, 3/16" Drill Bits, T-25 Driver Bit, Drill Bit Extender, Tape Measure, Socket Set, Speed Square

### Mount Fe<sup>26</sup> Posts\*

- Wood Blocking tied to deck frame must be installed and constructed with treated dimensional lumber with a minimum thickness of 1-1/2".
- Position the edge of Fe<sup>26</sup> Post base plate a minimum of 1/2" from the inside edge of rim joist.
- Mount Fe<sup>26</sup> Posts at appropriate points based on panel length.
- Attach Fe<sup>26</sup> Posts with 3/8" X 3-1/2" Hex Head Galvanized Bolts.

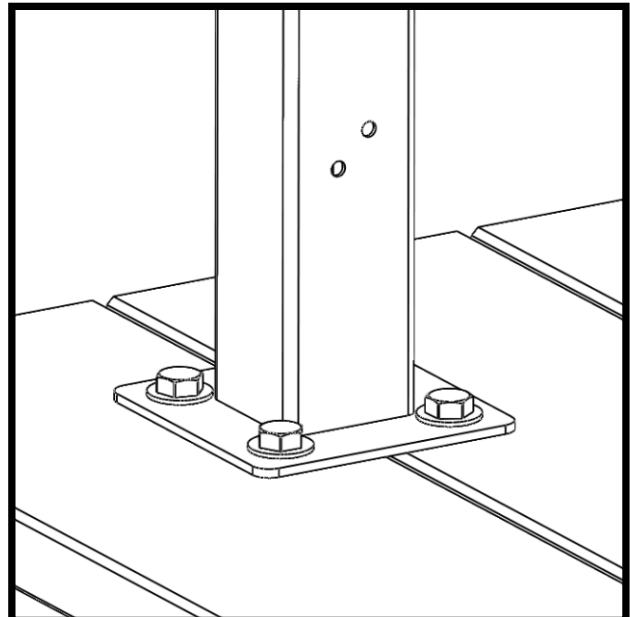
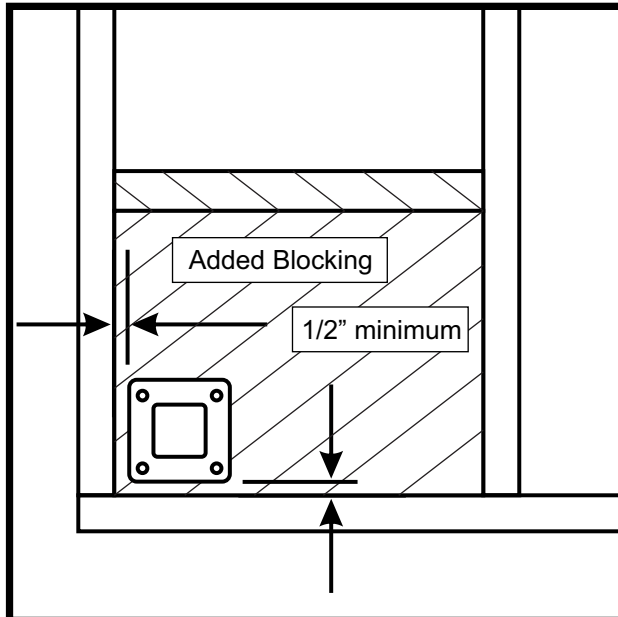

\*Reference Fortress Fe<sup>26</sup> Post mounting instructions

## Fortress Vertical Cable System Installation with Fe<sup>26</sup> UB-05 Brackets

Install Posts and UB-05 brackets. Brackets should be spaced according to the height of Fortress Vertical Cable Panel system being installed. Fortress Vertical Cable Panels are 34" or 40" systems.

Reference Fe<sup>26</sup> UB-05 instructions for bracket installation.

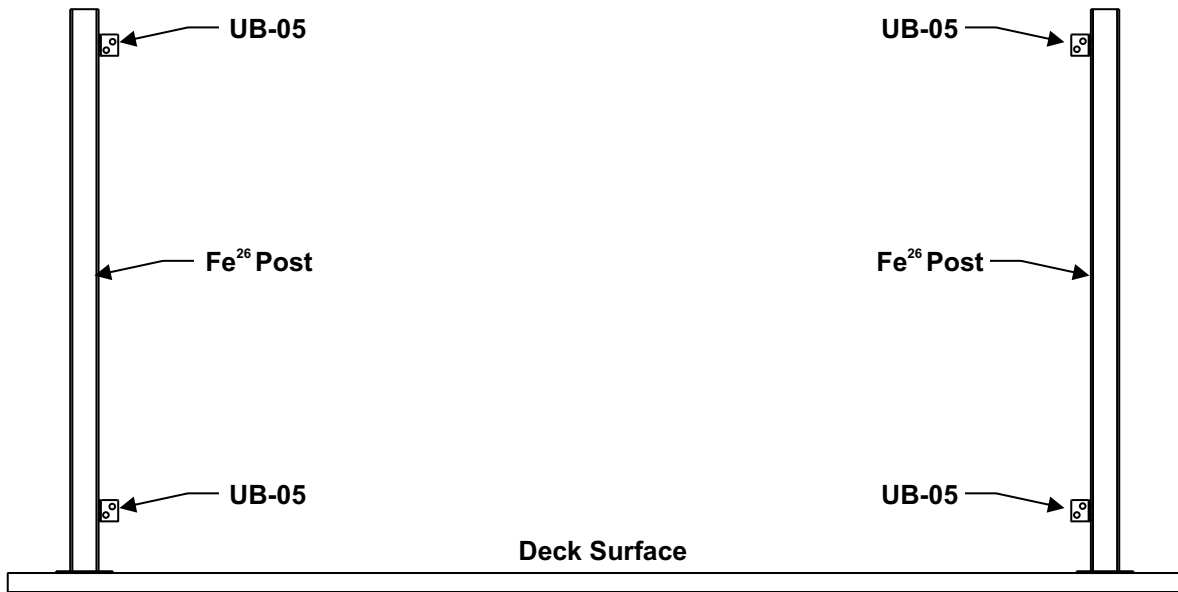

## UB-05 Bracket Top and Bottom Locations for Fortress Vertical Cable System Installations

Pre-Drilling with a 3/16" drill bit is required.

Rail Panel Height	Pre-Drill Dimensions			
	A*	B	C	D
34"	3-5/8"	5-1/8"	36-3/8"	37-7/8"
40"	3-5/8"	5-1/8"	42-3/8"	43-7/8"

\*Dimension A positions bottom edge of rail 3-3/4" above deck surface.

\*Dimension A is measured from the bottom surface of post base.

Remove all metal shavings from deck, post base cover, post, and panel before bracket is screwed to post to prevent rust stains.

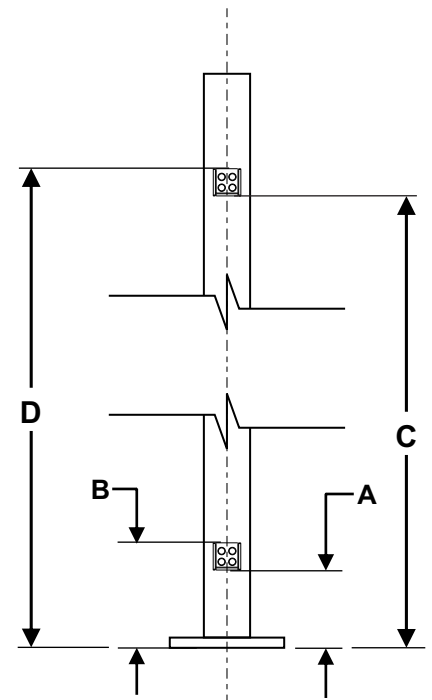

## Install Fortress Vertical Cable System into the Fe<sup>26</sup> UB-05 Brackets

- Remove Fortress Vertical Cable Panel System from packaging. Loosen but do not remove all of the hex nuts so that cables are completely slacked.
- **If rails need to be cut shorter. Vertical Supports and Cables can be repositioned to maintain even spacing.**
- **To remove a cable, completely remove the hex nut and pull the cable assembly through the bottom rail.**
- Insert top and bottom rails into recently installed brackets.
- Using a 3/16" drill bit pre-drill the top and bottom rails at each UB-05 Bracket. Secure top and bottom rails to UB-05 Brackets with supplied T-25 Thread Cutting Screws. Only one screw is required to secure the rail at each UB-05 bracket.

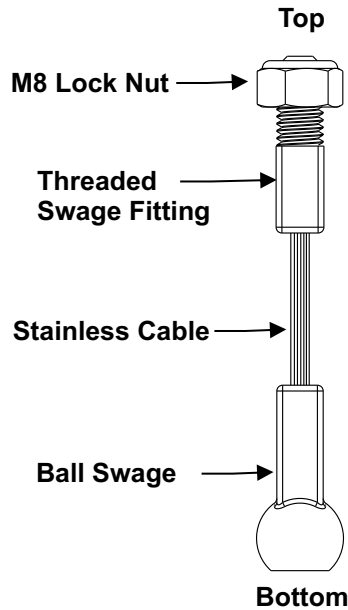
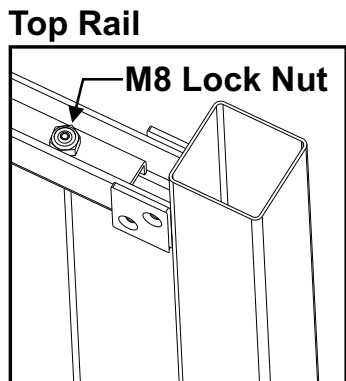

## Tightening the Fortress Vertical Cable System

Use a 13mm Socket Wrench Tighten the cables in the sequence shown below. **ONLY TURN HEX NUTS ONE COMPLETE TURN AT A TIME.** Repeat the tightening process until all cables are tensioned equally.

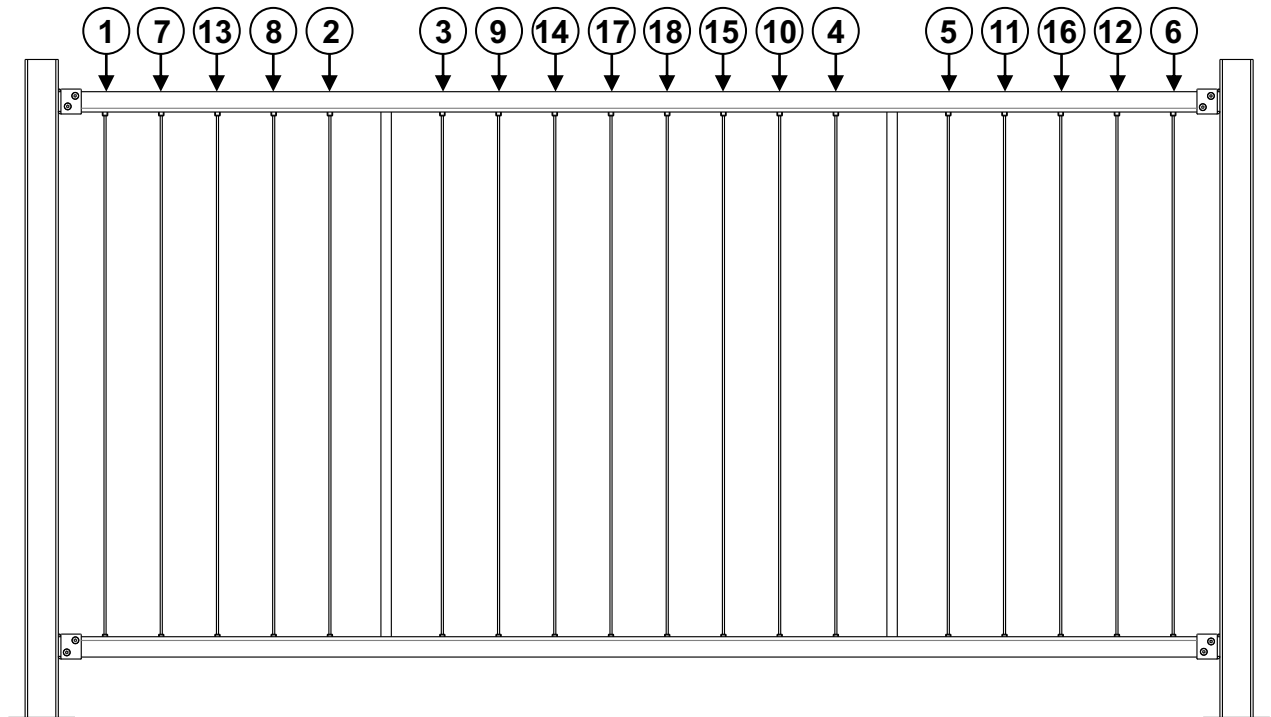
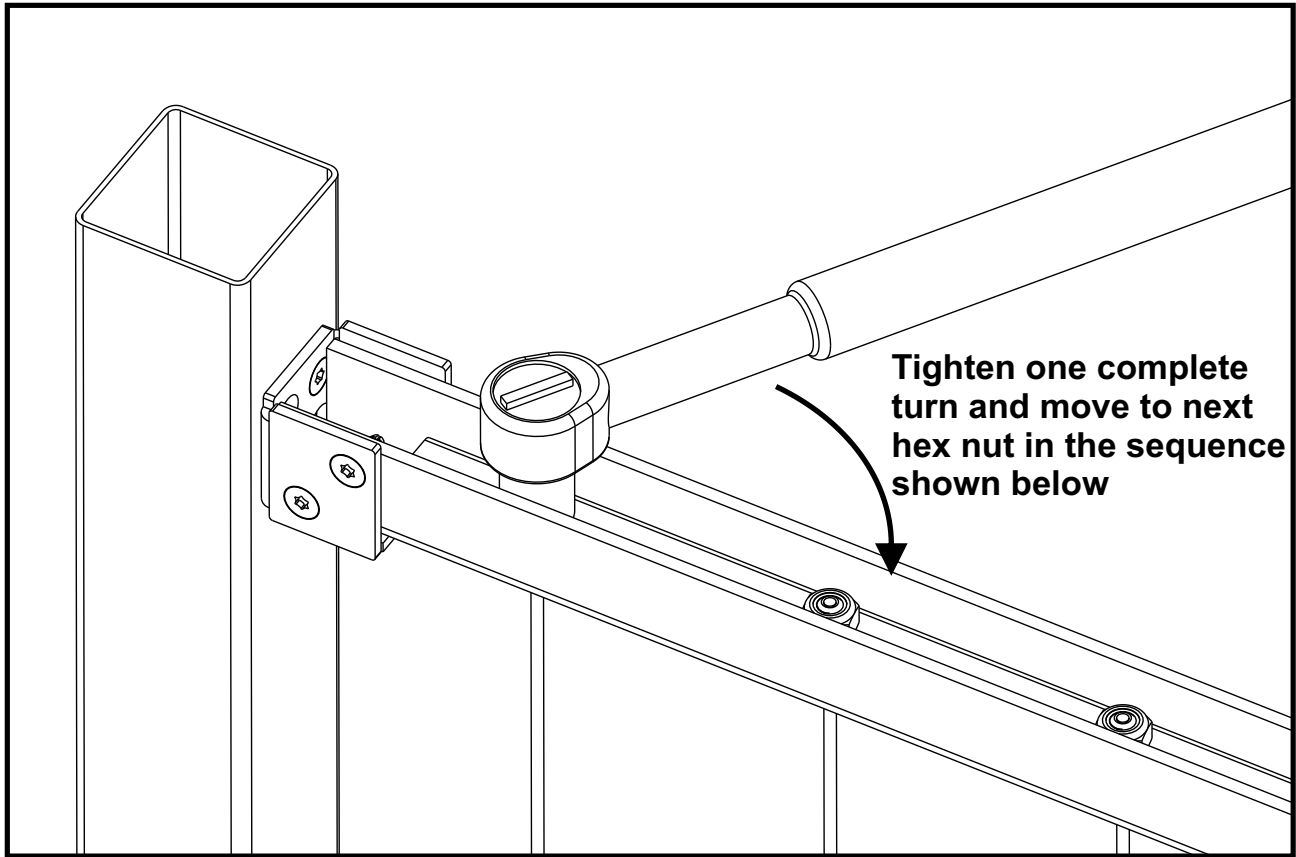

## Install Wood Top Cap - Option 1

Use a Wood Top Cap to finish the Top Rail. Cut Wood Top Cap to length and secure to Top Rail with Fortress Cap Rail Clips. Cap Rail Clips should be equally spaced along the length of Wood Top Cap.

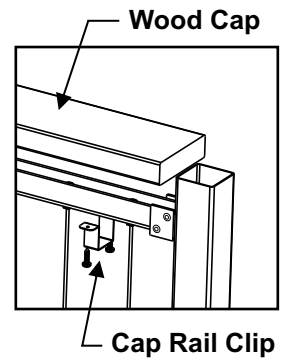
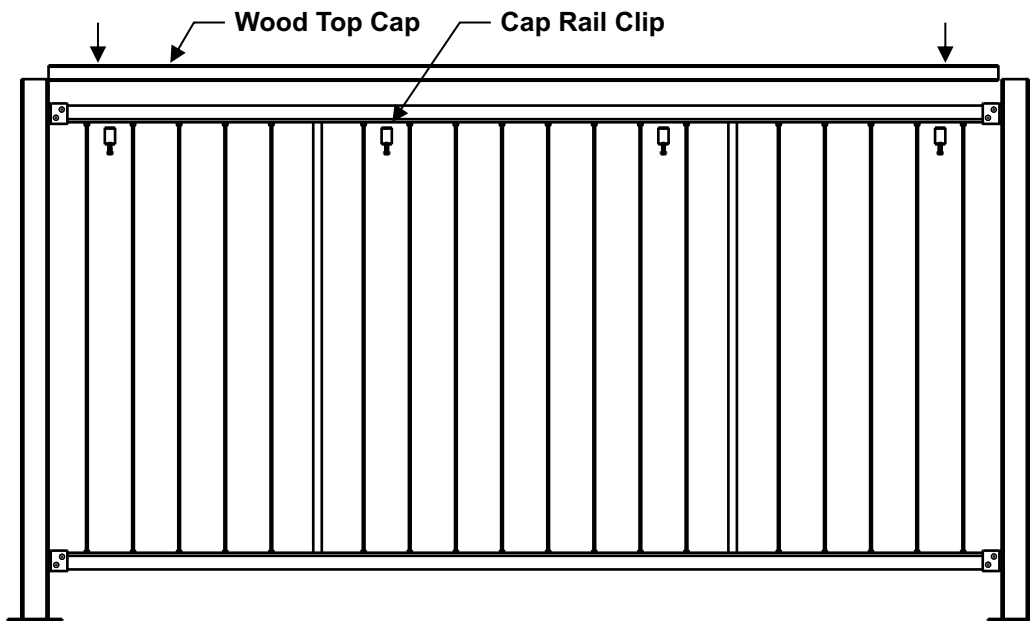

## Install Flat Accent Rail - Option 2

Use a Fortress Flat Accent Rail to finish the Top Rail. Secure Accent Rail to top of the panel by slipping over the top of the UB-05 Brackets.

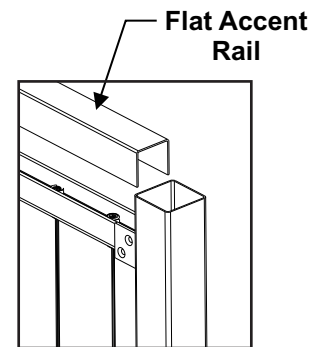
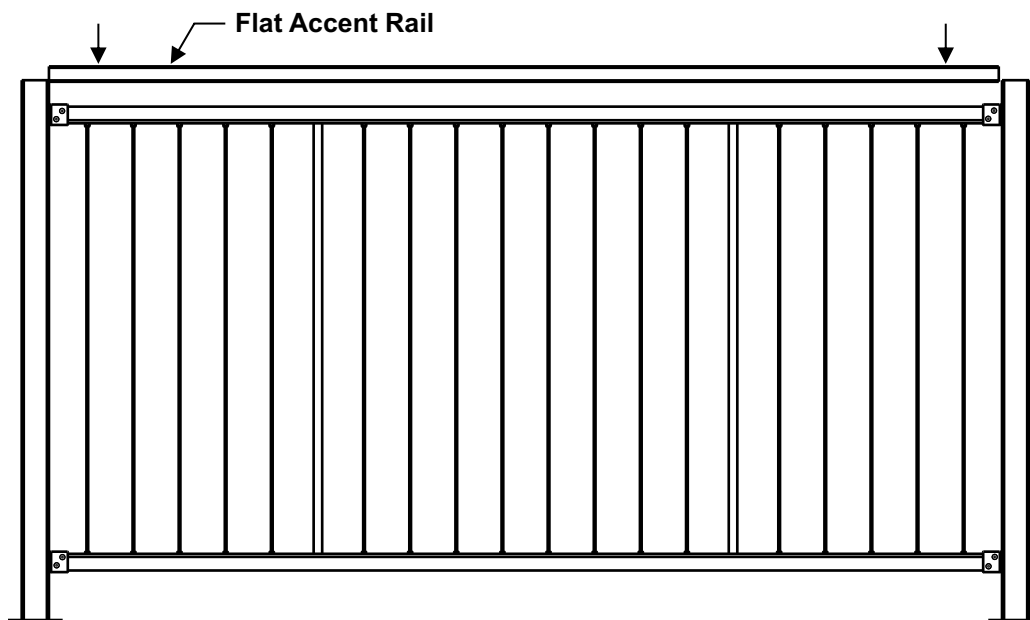

## Install UB-05 Caps

Install UB-05 Caps. When using a Wood Top Cap and installing the UB-05 Caps on the Top Rail, the Caps should be installed upside down as shown. If using a Fortress Flat Accent Rail, UB-05 Caps will not be used on the Top Rail.

